

PainsWessex

Emergency Rations: Survival Nutritional Pack

Pains Wessex Emergency Rations provide high energy food for emergency survival. Approved world-wide for use on board lifeboats and liferafts, our compact emergency rations have been developed to offer the highest quality rations manufactured under stringent German standards.

- + Specially developed to minimise size, making them more cost effective to transport and store than other ration products on the market
- + Made with quality ingredients the rations are vegan, nut free and made without GMO, to maximise usability.



DESCRIPTION

Pains Wessex survival ration food box conforms to ISO18813:2022 and is approved by Lloyds Register and the USCG to meet the requirements for survival food. The pack consists of nine high energy wrapped bars in a vacuum sealed alu-foil pack to maintain freshness.

Each food pack weighs 500g (17.64 oz) providing an average 10,150kJ of energy meeting all the worldwide regulations. The packaging has been thoroughly tested to provide product durability and keeps fresh for 5 years.

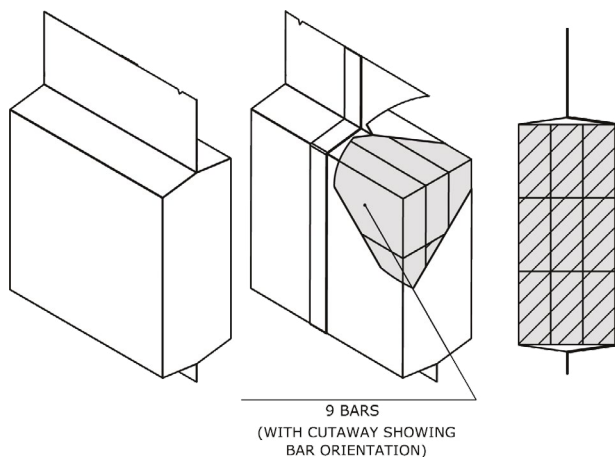

ENG	CHI	JAP	NOR	GRE	FRE	SPA	GER	
Nutrition facts per	营养成分 (每份)	あたりの栄養成分	Næringsfakta pr	Διατροφικά στοιχεία ανά	Informations nutritionnelles par	Datos nutricionales por	Nährwertangaben pro	100 g
Energy	能量	エネルギー	Energi	Ενέργεια	Énergie	Energía	Energie	2,030 kJ / 484 kcal
Fat	脂肪	脂質	Fett	Λίπος	Graisses	Grasa	Fett	19.6 g
- of which saturates	- 饱和脂肪酸	- 飽和分	- hvorav mettede fettsyrer	- εκ των οποίων κορεσμένα	- dont saturées	- de la cual saturada	- davon gesättigte Fettsäuren	10.7 g
Carbohydrates	碳水化合物	炭水化物	Karbohydrater	Υδατάνθρακες	Glucides	Carbohidratos	Kohlenhydrate	67.2 g
- of which sugars	- 糖	- 糖分	- hvorav sukkerarter	- εκ των οποίων σακχάρα	- dont sucres	- de los cuales azúcares	- davon Zucker	12.7 g
Protein	蛋白質	タンパク質	Protein	Πρωτεΐνη	Protéines	Proteína	Eiweiß	8.5 g
Salt	盐	塩	Salt	Άλας	Sel	Sal	Salz	<0.03 g

FEATURES

- Compact size for ease of transport and storage
- Ready to use, consumed directly from the packet
- 5 years shelf life
- Vacuum packed and watertight alu-foil.
- Vegan
- GMO and nut free
- Dropped and tumble tested to ensure durability.
- Contains optimal ratio of balanced nutrition to volume.
- Approvals Complies with: ISO 18813:2022 and SOLAS IMO Resolution MSC.48(66) LSA Code as amended

INGREDIENTS

Wheat flour, vegetable fat (palm), sugar, may contain traces of milk and soy.

LOGISTICS

Box Dimensions	H 105mm W 112mm D 47mm
Carton	17 units
Net Weight	8.5kg
Gross Weight	9.5kg (20.95lb.)
Carton Dimensions	375 x 270 x 155 mm
Volume	0.016 cbm

MANUFACTURE

Manufactured by survival solutions specialist Wescom Group, the Pains Wessex brand Emergency Drinking Water is manufactured to the highest quality control standards, in a purpose built production facility in Bremerhaven, Germany.

AVAILABILITY

Available from Wescom Group's global distribution partners.