



## APPLICATION

The new Francis LED Twinhead searchlight range continues to develop and offers an Efficiently and Environmentally Friendly alternative to traditional lamp sources.

Using the highest grade of CREE LED, this range offers a high power output with low power consumption. In addition, the CREE XLamp Series offer a lamp life of 33,000 hours

Francis Searchlights have developed and improved all remote controlled searchlights across the range still further by adding full variable speed, a new modern and sleek joystick control panel, using membrane and LED technology, offering Bus Control, auto home position setting, all at no extra cost, with Optional Controls available on request.

The Francis bus (FBUS) is a custom communication protocol based on RS485 two-wire bi directional communication hardware. The system provides a simple bi directional link between searchlights and control panels.

As with all Francis products, the construction is robust and of the highest quality of construction. Utilizing excellent thermal management of the LED chip ensures successful performance and chip life.

The 110w LED gives illumination characteristics similar to

## SPECIFICATION

- 33,000 lamp life hours.
- Toughened super clear Optiwhite front glass.
- Parabolic glass reflector
- Constructed from marine grade materials and fixings.
- Powder coated and stove enamel paint finish.
- Pan rotation 365°.
- Tilt elevation control  $\pm 35^\circ$ .
- Variable speed LED joystick, with auto home position.
- RS485 connectivity. Dimmable Control Panel.
- Variable Rotation Speed 1 to 19°/sec (Pan).
- Variable Elevation Speed 1 to 6°/sec (Tilt).
- Heater fitted in gearbox & barrel.
- Operational temp  $-50^\circ$ .
- Up to 27,800 Lumens.
- Colour Temp options 6500k.
- High quality control gear 50/60 Hz 1ph.
- Sealing - IP66 Gearbox, IP66 Searchlight, PSU IP66.
- Searchlight weight 40kgs, PSU weight 5kgs.
- Remote Focus fitted as standard.

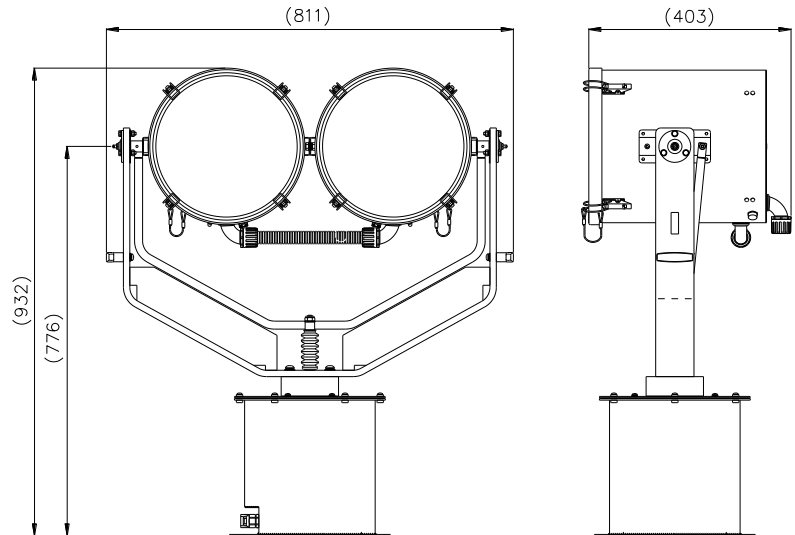

## ALL DIMENSIONS IN MILLIMETRES

Base fixing details:

4 holes 12.5  $\varnothing$  equi-spaced on a 290mm PCD  
Joystick panel 150 x 150mm (106 x 136mm cutout)

PSU dimensions: 360 x 400 x 155mm

### Part Numbers

Type	Supply	Watts	Part No
L300RC	115/230v	220w	A7232
L300RC	24v	220w	A7233

### Optional Controls:

Program Record Function  
Computer Control Software  
Azimuth LED Control Panel  
Master Control Panel (control up to 10 Searchlights)  
Slave Control Panels (with full control)  
Fiber Optic/TCP/IP Connections

VAC	LED life	Range @ 2 Lux	Luminous Flux	Div	Watts
115/230v	33,000 hrs	1089m @ 7°Div	27,800	7-20°	220w

**Francis Searchlights Limited**

**Union Road, Bolton, BL2 2HJ, UK**

**Tel 44 (0) 1204 558960 Fax 44 (0) 1204 558979. Email sales@francis.co.uk. Web site www.francis.co.uk**