

Overhead Drum lifter



The Overhead Drum Lifter is designed for straight vertical drum lifting using an overhead crane.

The Lifter also features integral fork pockets to allow use with a forklift.

Unique saddle design allows use with 30 and 55 gallon steel, plastic and fiber drums and the integral ratchet strap securely holds the drum in place.

Fork Pockets on Center = 18".

Welded carbon steel construction features a durable powder-coated safety yellow finish.

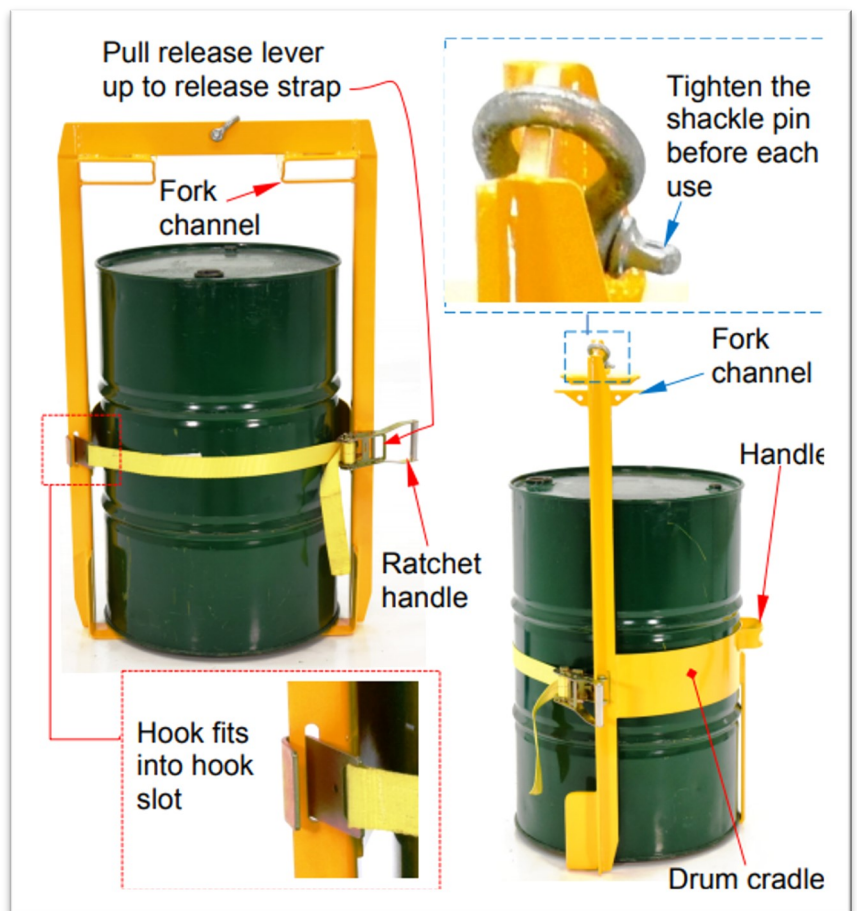

Overhead Drum lifter



SPECIFICATIONS

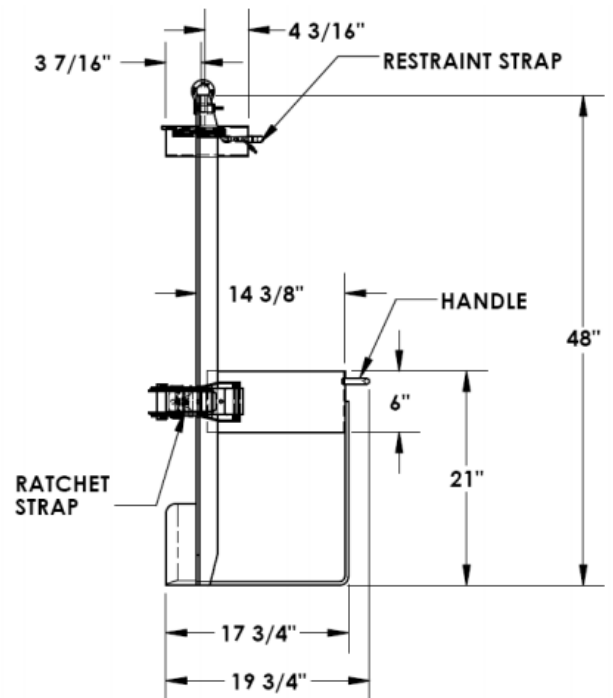
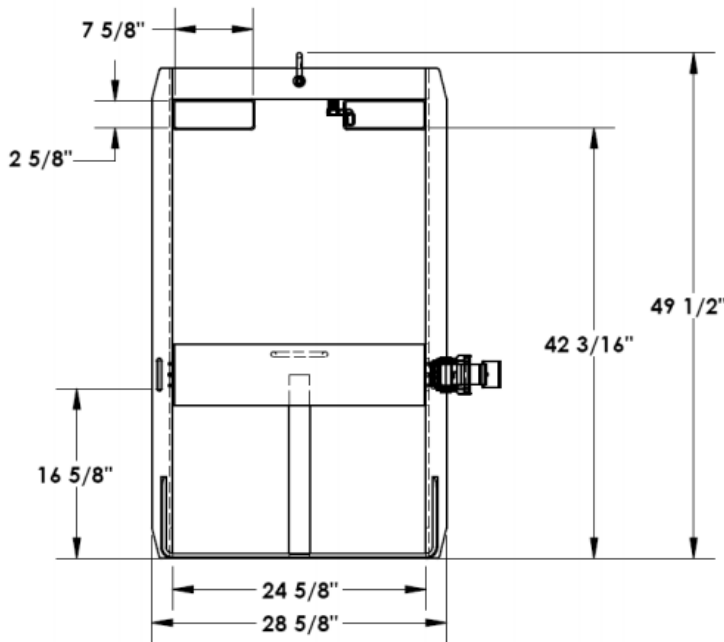

Only use with 114L (30 gallon) and 209L (55 gallon) drums in upright position.

Compatible with steel, plastic & fiber drums

Capacity = 454.5kg (1000 lbs)

Weight = 39.1kg (86lbs)

Overall width = 72.7cm

Overall length = 50.2cm

Overall height = 125.7cm

Can be attached to a hoist or mounted on forklift or crane

Usable fork channel dimensions = 16.5cm x 5.1cm

Ratchet strap to secure drum in lifter

EXPLODED VIEW AND BILL OF MATERIALS

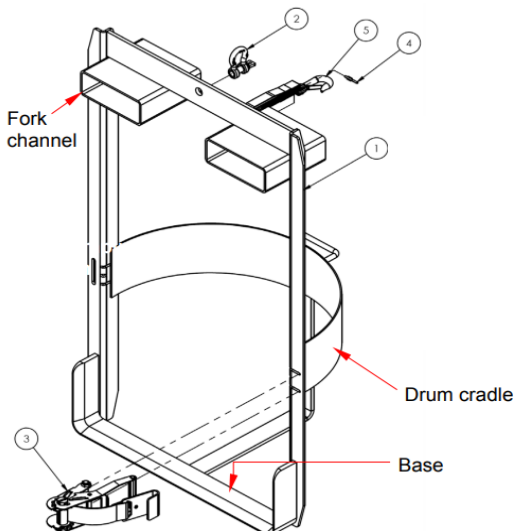

Item	Description	Qty
1	Weldment, frame	1
2	1/2" 2-ton shackle	1
3	Ratchet strap, dual	1
4	Quick link, zinc finish	1
5	Fork attachment restraint	1