



## TECHNICAL DATA SHEET

**NEW**

# Internal Lifeboat Light SL-500

Daniamant design and manufacture all of our products in line with the relevant worldwide approvals, technical specifications, current legislation and International directives.

Our mission is to achieve World class performance through partnerships with our suppliers, customers and employees, providing products and services that enhance the safety and security of our customers.

#### Daniamant products cover 11 key areas:

- Lifejacket Lights
- Liferaft Lights
- Lifebuoy Lights
- Intrinsically Safe Lights
  - Special Lights
  - LED Flares
- Bridge Navigational Watch Alarm System (BNWAS)
  - Salinometers
  - Oil Level Alarm
- Electronic Inclinator
- Agency for a range of world-renowned safety product brands (supplied to the Danish market)

#### Further Information

For further information on our products, please see our website: [www.daniamant.com](http://www.daniamant.com)

MODEL	SL-500
Part number	24-501A
Plastic Colour	Yellow
Light - Output	Minimum 0,5cd – average 5,3 cd
Light - Duration	Minimum 12 hours
Light - Type	Steady
Material	ABS
Storage Temperature	-52 C to +65 C
Operating Temperature	-52 C to +65 C
Storage Life	Requires annual inspection
Weight - Nominal	294 g
Power	10-30V DC
Activation	External power
Approvals	In compliance with SOLAS CH III Life-Saving Appliances
- Classification Societies	
Approvals - Country	

## Transport Specification

Transport Regulations are subject to change. Please refer to the latest Product safety Data Sheet at [www.daniamant.com](http://www.daniamant.com) for details.

## Accessories

Cable length can vary on request, please contact Daniamant for details.

## Packing Specification

To minimize shipping costs, all Lifeboat Lights are packed and supplied in boxes of 10 off.

#### The dimensions are:

Box of 10 off : 58 x 24 x 22 mm

#### Approximate packed weights are:

Box of 10 off : 5,5 kg

**Daniamant Ltd**  
 Unit 3, The Admiral Park  
 Airport Service Road  
 Portsmouth, PO3 5RQ  
 United Kingdom

Tel +44 23 92 67 51 00  
 Fax +44 23 92 67 51 01  
 sales@daniamant.com

**Daniamant ApS**  
 Industrivej 24C  
 3550 Slangstrup  
 Denmark

Tel +45 47 37 38 00  
 Fax +45 47 37 38 09  
 orders@daniamant.com

**Daniamant Electronics A/S**  
 Industrivej 24C  
 3550 Slangstrup  
 Denmark

Tel +45 47 37 38 00  
 Fax +45 47 37 38 09  
 info@daniamant.com

**Outline**

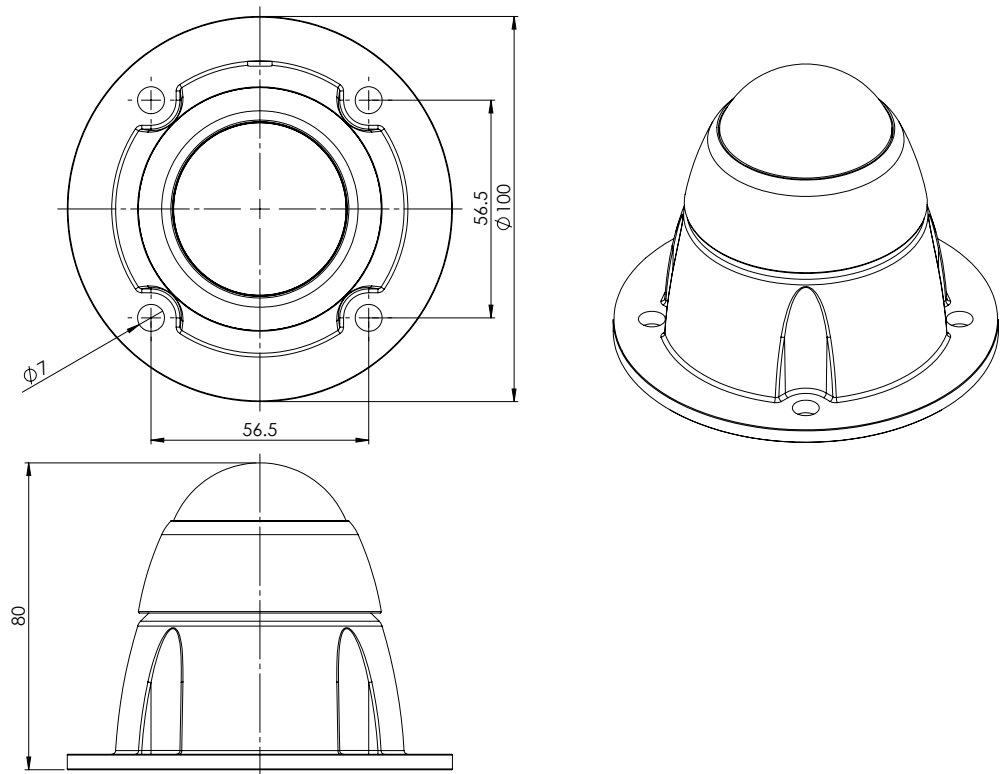

**Installation**

Use stainless steel screws, mounting must be on a flat surface.  
 Connect the cable to the external power-supply (10-30 VDC), observing the correct polarity.